

VoiceLink IV



Infrared Sound Field System

User Guide

TeachLogic

SAFETY INSTRUCTIONS

- 1. Read Instructions:** *All safety and operation instructions should be read before operating this TeachLogic product.*
- 2. Retain Instructions:** *Safety and operating instructions should be kept for future reference.*
- 3. Water & Moisture:** *This product should not be operated near water.*
- 4. Heat Environment:** *Do not subject this product to excessive heat conditions.*
- 5. Power Source:** *This product must be connected to an AC power source per the voltage input specified and marked marked on the power supply.*
- 6. Power Cord Caution:** *Power cable should be routed clear of foot traffic and supported clear of kinking or abrasion.*
- 7. Object Protection:** *Locate the operating unit so it will not be subjected to falling objects or water entry.*
- 8. Internal Service:** *User should not attempt to service this product. All internal service must be accomplished by a qualified technician.*
- 9. Electric Shock:** *Do not adapt or modify the AC power plug thus lifting the earth ground connection.*

VoiceLink - Infrared Wireless Microphone System

The VoiceLink IV is an *infrared* wireless microphone system that can be added to any sound system. It can be a supplement to a Bogen or TOA sound reinforcement system or an addition to an Extron or Crestron multi-media system. You now have the capability of using four (4) wireless microphones anywhere in a conference room, boardroom, courtroom, or classroom.

The system is comprised of a domed sensor installed on the ceiling. The sensor receives the IR wireless signal from the microphone/transmitter and sends a composite signal to the receiver. The receiver transforms the composite signal into an analog audio signal which is fed to the multi-media amplifier. The amplifier then powers the speakers for enhanced sound distribution throughout the room for improved the listener comfort and intelligibility for all.

The wireless transmitter gives complete freedom of movement anywhere in the room. Two transmitters can be the Crescent style worn under the chin, a pendant style worn around the neck or a body-pack clipped to the waist with an external microphone plugged in thus rendering hands free mobility. In addition, two handheld wireless microphone / transmitters can be used simultaneously by other attendees or interactive group participation.

A noted feature of infrared signal transmission is that it is confined within the room. The transmission signal will not penetrate walls, ceiling or floor; thus providing 100% security. It also eliminates cross talk or interference with adjoining rooms. An added benefit, all systems operate on the same transmission frequencies, therefore; all transmitter / microphones will work in any room equipped with the same VoiceLink system.

Easy to install - Easy to use

VoiceLink IV Receiver IR-468N

The VoiceLink IV (IR-468N) is a four channel receiver for simultaneous reception of four Infrared wireless microphones. It receives a composite signal from a dome sensor, processes it and produces a balanced analog audio output for each microphone or a combined balanced output of all microphone inputs to be fed to the input of an amplified sound system. It features a volume control and signal presence indicator for each microphone.



Front Panel

Power Switch with an associate “Red” LED to indicate presence of power.

Channel: A, B, C, D volume controls for independent volume control for each wireless IR transmitter input.

IR Transmission Indicator: A “Green” LED will light when the corresponding transmitter for that channel is turned “ON”, informing you that a transmission signal is being received



Rear Panel

Phone Jack (1/4") is an unbalanced output of combined channels A, B, C, D.

Line / Mic Switch selects the output signal to be either "Line" or "Mic" level.

One male XLR Connector is a balanced line level output of combined channels A, B, C, D.

Four male XLR Connectors are balanced line level outputs for each respective channel.

Sensor Connection (RCA) Each sensor connection provides phantom power to a sensor and receives a composite FM signal from the sensor. Four (4) sensor inputs allow installation of multiple sensors for odd shaped or large rooms. *(Normally only one sensor is required)*

Power Input Jack connects to the power supply, 12-15 volts DC, 1 Amp.

Infrared Dome Sensor (ICS-55) The ceiling dome sensor is a highly sensitive infrared receptor and provides optimum performance. One dome sensor comes with the VoiceLink IV system. The sensor needs to be installed on the ceiling. It comes with a T-Bar twist-on mounting/support bracket and 50 feet of plenum rated cable with RCA connector on each end. The ideal location for the dome sensor would be in the center of the ceiling. This will provide a clear signal path for IR transmission from the transmitter to the dome sensor without obstruction. In addition, you will have 360° coverage and will minimize the transmission distance for more reliable performance. It collects the infrared transmission signal via 6 large detecting diodes with magnifying lens. The sensor is connected to the mixer/amplifier via the plenum rated dual shielded cable.



Drop-in Battery Chargers

The battery chargers are specifically designed to recharge NiMH batteries. They charge the batteries at an optimum rate and turn “off” at end of charge. The chargers feature a recycle function, which is used to restore the battery charge capacity and extend their service life.

BRC-50 charger recharges the Crescent (IRT-30) or Body-Pack transmitter (IRB-30) and Handheld (IRT-35). You merely place the Crescent, Body-Pack, Handheld in their respective slot. Connection will be made and charging will commence. Charger will automatically control the rate and maintain the charge.



BRC-101 provides a charging port for the pendant or a handheld microphone. In addition, a tray provides insertion of two “AA” NiMH batteries for recharging.



BRC-202 is a dual charger for charging two pendants or two handheld microphones or one of each.



All drop-in chargers feature regulated charging rate, full charge maintenance, recycle function and auto protection against incorrect battery insertion.

FOR USE WITH RECHARGEABLE NiMH BATTERIES ONLY.

Infrared Transmitters

Crescent (IRT-30)

The Crescent is a lightweight microphone/transmitter designed to be worn under the chin suspended by an adjustable lanyard. The Crescent shape was designed for efficient performance and user comfort. The dual internal microphones render optimum voice pick up and quality reproduction. The Crescent provides an auxiliary input (3.5mm) to accommodate the insertion of an iPod™ or similar device for supplementary program material.



A soft touch mute button cuts the microphone “off” for private conversation (the power LED will flash in the mute position). A volume control allows adjustment of the microphone volume. The external battery contacts accommodate the convenient use of a drop-in charger.

An optional Plug-in microphone (LM-300) can be plugged into the aux input for enhanced performance. Although the built-in microphones give satisfactory performance, the plug-in microphone has a unidirectional element resulting in additional sensitivity for more gain (more volume) before feedback.

Pendant Transmitter (IRT-89) with built-in microphone. The pendant transmitter is usually worn around the neck for hands free movement. However, it can easily be removed from the lanyard and used as a handheld microphone. Two lanyards are provided: one with fixed length and safety breakaway clasp and a longer adjustable cord style. The 10 transmitting diodes are located in the top portion for very efficient IR transmission. The power switch is accompanied by a battery level LED (Green=Useable, Red=Needs Charge). The A-B switch selects the transmission channel. The pendant is conveniently inserted in either the BRC-101 or BRC-202 for recharging.



An optional Plug-in microphone (LM-300) can be plugged into the top of the pendant for enhanced performance. Although the built-in microphone gives satisfactory performance, the plug-in microphone is a unidirectional element resulting in better vocal quality and much more gain (more volume) before feedback.

Body-Pack Transmitter (IRB-30), usually worn on the waistband, is the component that transmits the IR signal to the sensor. The IRB-30 has 10 emitting diodes on its front panel and is powered by two rechargeable NiMH batteries. Controls include a power “on/off” switch and a mic gain control. Battery level indicator LED: Green = useable charge, Red = low battery.



It is required to plug in an external microphone. There are several optional microphones available and they plug into the top of the IRB-30. The IRB-30 is equipped with a belt clip for waist attachment.

Caution: The body-pack cannot be placed in pocket. The red window cannot be obstructed, those are the emitting diodes.

Plug-in Microphone (LM-300) is a small capsule size microphone that plugs directly into the top of the IRB-30 body-pack. A lanyard cord is provided to accommodate wearing the body-pack transmitter around the neck and utilizing it as a pendant microphone. A windscreen is included to prevent breath pops when used in close proximity to the mouth.



Ultra Lite Microphone (ULM-835) is a miniature boom style microphone supported by a wire around the left ear. The mic boom extends along side of face and has a unidirectional microphone with windscreen. The small ring on the boom prevents perspiration from entering the mic element. Aside from comfort, the boom style mic renders the best performance in terms of sound quality and is not prone to feedback.



Caution: The boom can be formed to fit but it is not a flexible boom. Do not bend back and forth. IT WILL BREAK !

Collar Microphone (CM-835) is a flexible rod that is formed around the neck. The end with the microphone and windscreen is then contoured up toward the mouth. The cord exits the rod in the center in back, out of the way, and is plugged into the body-pack. The collar mic utilizes a unidirectional mic element to minimize feedback and renders quality voice reproduction.



Lapel Microphone (LM-835) is a small capsule microphone with a spring clip for securing on to a clothing edge. The lapel microphone is well suited for out of sight application.



However; as a result of the microphone being farther away from the mouth, more gain is required for adequate volume. An omni-directional microphone element is used to pick up from all directions. These two factors make the lapel microphone most prone to feedback when used near or under a speaker.

Handheld Microphone Transmitter (IRH-35 channels “A” and “B”) is most applicable for presenter’s use or audience participation. It has an “on/off” switch and a battery level indicator LED; Green=useable charge, Red=low battery. The transmitter has 10 emitting diodes around the top and bottom of the handle. The metal housing provides low handling noise and insures durable longevity.



Handheld Microphone Transmitter (IRH-40 with blue collar ring utilizes channels “C” and “D”) is most applicable for presenter’s use or audience participation. It has an “on/off” switch and a battery level indicator LED; Green=useable charge, Red=low battery. The transmitter has 10 emitting diodes around the top and bottom of the handle. The metal housing provides low handling noise and insures durable longevity.



Body – Pack Transmitter and its Features

- An external microphone needs to be plugged into the Body-Pack
 - The Plug-in microphone (LM-300) is a small capsule that plugs directly into the top of the body-pack transmitter. Slip the lanyard over your head and clip Body-Pack to lanyard, use as a pendant type microphone.
 - The Lapel microphone (LM-835) plugs into the mic input and then the lapel mic is clipped to your clothing.
 - The Collar microphone (CM-835) plugs into the mic input and the collar is formed around the neck with the microphone element oriented toward your mouth.
 - The Ultra Lite microphone (ULM-835) is fitted around the ear and the cable plugged into the mic input.
- The Body-Pack is powered by two rechargeable NiMH batteries which need to be fully charged for optimum performance
- Turn “on” the Body-Pack via slide switch on side of the Body-Pack
- Observe the Green LED on top of transmitter indicating a useable charge on battery.
- Also observe the LED next to either A or B channel volume control, indicating IR signal being received when the Body-Pack is turned “on”
- To change channel, remove the battery cover and slide the channel selector switch to A or B.
- Speak into the microphone and adjust the volume using the gain control on top of the Body-Pack.
- While talking, walk around the perimeter of the room to verify 100% reception of the signal.
- Upon completion of test, put the Body-Pack in the charger for recharging

Drop-in Battery Charger (BRC-50)

The battery charger is a rather sophisticated charger. It will charge the NiMH batteries at the optimum charge rate, maintain full charge, and will recycle the batteries for extended battery service life.

- Place handheld microphone and/or body-pack transmitter into their appropriate slot
- When a microphone is being charged, a Red LED will light indicating unit is being charged
- When the batteries are fully charged, the LED will change to Green.
- There is an audible buzzer which will buzz an alert when the batteries are fully charged. The buzzer can be turned “on or off” with the slide switch located on the bottom of the charger. (The charger is normally shipped with the switch in the “off” position).

Handheld Microphone Transmitter IRH-35 channels A & B

- The handheld microphone is powered by two rechargeable NiMH batteries which need to be fully charged for optimum performance
- Turn “on” the microphone with slide switch and observe the Green LED
- Also, observe the LED next to Ch. B volume control indicating IR signal being received when the microphone is turned “on”
- If the Ch. A LED turns “on”, unscrew the bottom half of the handheld and slide the channel selector switch to Ch. B.
- Speak into the microphone and adjust the volume using Ch. B volume control on the VoiceLink IV.
- While talking, walk around the perimeter of the room to verify 100% reception of the signal.
- Upon completion of test, put the microphone in the charger for recharging

Handheld Microphone Transmitter IRH-40 channels C & D

Blue collar handheld transmitter/handheld microphone

- The handheld microphone is powered by two rechargeable NiMH batteries which need to be fully charged for optimum performance
- Turn “on” the microphone with slide switch and observe the Green LED
- Also, observe the LED next to Ch. D volume control indicating IR signal being received when the microphone is turned “on”
- If the Ch. C LED turns “on”, unscrew the bottom half of the handheld and slide the channel selector switch to Ch. D.
- Speak into the microphone and adjust the volume using Ch. D volume control on the VoiceLink IV.
- While talking, walk around the perimeter of the room to verify 100% reception of the signal.
- Upon completion of test, put the microphone in the charger for recharging

Installation of System

Location of receiver is primarily determined by user accessibility and availability of an electrical outlet. Location of the sensor and routing of the sensor cable is a more critical issue. It is important to observe a central location for the sensor and adherence to the guidelines for the routing the sensor cable



Location of Receiver

Select a location that is close to a standard wall electrical outlet

Receiver on a shelf or cabinet

Under shelf or shelf mount with SM-700 shelf mount kit



Rack mount kit RM-468



Route sensor cable from dome sensor to receiver



Interface to Amplifier with shielded audio cable

Installation of the Dome Sensor

The ideal location for the dome sensor would be in the center of the ceiling. This will provide a clear signal path for the IR transmission from the transmitter to the dome sensor without obstruction. In addition, you will have 360° coverage and will minimize the transmission distance for more reliable performance.

INSTALLING THE INFRARED SENSOR

Attaching the infrared ceiling sensor

Installation 1 ----- Attach to T-bar Rail

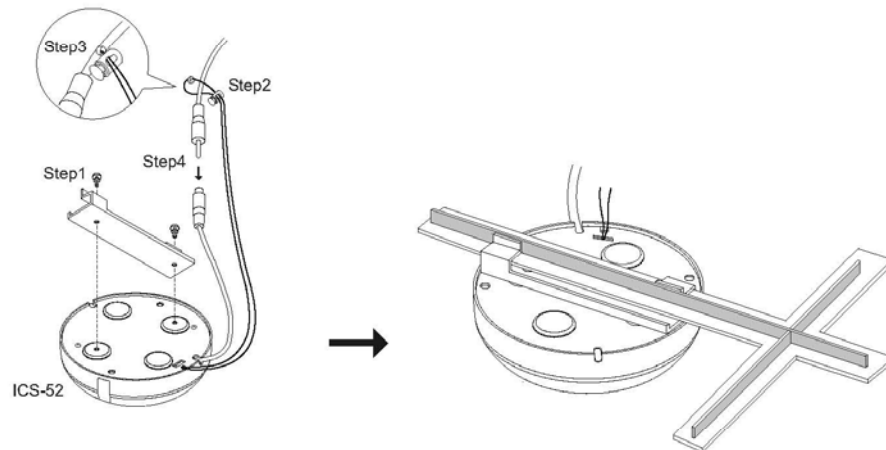

Installation 2 ----- Attach to wood surface

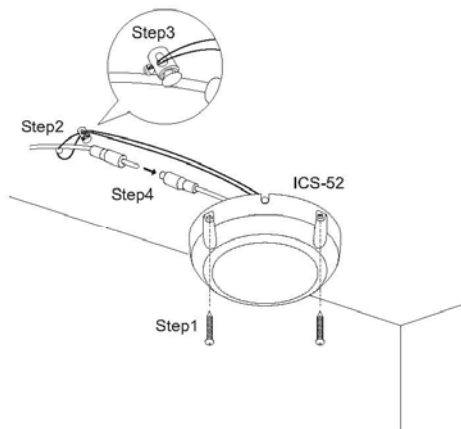

Installation 3 ----- Attach to concrete surface

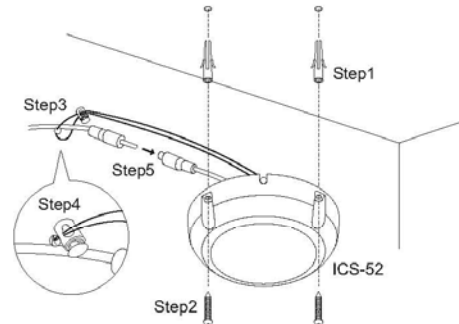

Final Connection of the VoiceLink IV to Audio System

- Power supply plugged into AC outlet, DC plug plugged into receiver
- Dome sensor plugged into sensor input, coil extra cable neatly and place out of view
- Connect receiver output to amplifier or media sound system
 - Each male XLR jack is a balanced line level output from each channel
 - Ch A-D mixed is a balanced composite line level output



- Unbalanced 1/4" phone jack, switchable to either "Line" or "Mic" level output
 - Sleeve - negative / ground
 - Tip – positive



System Operation

Now that the system is installed and connected, we are ready to turn the system “ON” and test its performance. The testing will be done using an IR transmitter (Body-Pack, Pendant or Handheld) to confirm good connectivity and quality audio.

- Turn the VoiceLink IV “ON” , Red power LED
- Confirm power to sensor, Green LED light in center of sensor
- Set volume of each channel “A” “B” “C” & “D” to mid scale (12” clock)
- Using a Transmitter (Handheld, Pendant, or Body-Pack with microphone)
- Select channel “A”
 - Pendant: “A – B” switch on front panel
 - Body-Pack: (open battery compartment) observe “ A – B” slide switch
 - Handheld: unscrew sleeve: Observe “A – B” or “C – D” switch on side of battery compartment
- Switch “ON” transmitter (Pendant, Body-Pack, or Handheld)
- Observe power LED (Green) - use fully charged batteries only
- Observe signal presence, Green LED on receiver adjacent to the channel “A” “B” “C” or “D” knob
- Performing test with a Body-Pack with mic plugged in or Pendant Transmitter
 - Slowly adjust volume control while talking into mic
 - Using Handheld transmitter, adjust volume on receiver
- Walk around the room while talking into microphone to confirm good IR connectivity

Caution: Be aware of walking under or in front of a speaker, feedback can occur

- Switch transmitter to channel “B” or “D” and repeat above performance test

Upon completion of performance test, the installation is complete.

TROUBLE SHOOTING GUIDE

Note: Most problems are directly related to low battery power. So please verify that the batteries are fully charged and less than two years old.

No Sound (Nothing works)	Check for power. Red LED next to power switch. Verify that AC outlet has power. Verify that the sound system works Verify dome sensor is receiving power, Green LED in center of sensor
Body-Pack or Handheld Transmitter does not work	Check batteries, Green LED when turned “on” Check microphone cable, wiggle back & forth at microphone and at connector end. Verify signal reception from transmitter to receiver, LED (green) adjacent to volume control.
Static, Noisy, or fuzzy Sound	Check charge on batteries. Check Hi / Lo switch inside battery compartment (Place in “Hi” position) Along side of battery barrel on handheld Verify that no other transmitter is turned “on” on the same channel. Bright sunlight, high intense fluorescent or halogen lights near sensor.
Dropouts	Verify that the infrared beam transmitted from the transmitter (dark red window) is not being obstructed by clothing or other solid objects. Dark colored walls have a tendency to absorb infrared and do not reflect efficiently. Glass windows and doors allow competing infrared light which weakens IR transmission. Persistent dropouts may require installation of an additional sensor.

Feedback (Mic Squeals)

Feedback is the result of a resonant sound coming from the speaker into the microphone creating a self generating closed audio loop.

This can only be avoided by not walking under or directly in front of the speaker.

Relocation of speaker is another consideration to prevent the close proximity of microphone to speaker.

Lapel microphones are the most prone to feedback because of distance from mouth to microphone. Therefore, if the problem persists, you may want to consider using another microphone such as a collar, headband with a boom, or a unidirectional microphone plugged into the pendant or body-pack with a lanyard worn around the neck.

To reiterate: Batteries in the transmitter is our greatest grievance. Life expectancy of “Duracell” batteries given conscientious care is about two years. We have experienced much shorter service life from other brands.

Batteries should be stored in a fully charged condition and stored in a cool place. Evidence of weakening batteries: (1) shortened service per charge, (2) batteries won't take a charge, (3) lack of output, causing noisy operation.

SPECIFICATIONS

IR-468N RECEIVER

Receiver Input	Infrared FM
Modulation	FM Wide-band
Reception Frequencies	Ch. A: 2.08 MHz Ch. B: 2.54 MHz Ch. C: 2.30 MHz Ch. D: 2.80 MHz
Infrared Wavelength	850 nm
Pilot Tone Signal	Ch. A: 32.768 KHz
De-emphasis	50 μ s
Frequency Response	40 Hz, -18KHz, \pm 3dB
S/N Ratio	>65 dB
THD	<1% @1KHz
Nominal Deviation	\pm 10 KHz
Maximum Deviation	\pm 25 KHz
External Sensor Input	Four, RCA
Connectivity Coverage	2,500 Sq. Ft.
Line Output	
Individual Balanced, XLR	Ch A, Ch B, Ch C, Ch D
Composite Balanced, XLR	Ch A - D
Composite Unbalanced	Ch A - D
1/4" phone jack	Switchable Line/Mic Level
Power Supply	15VDC / 1.5A / 15W
Dimensions	17" W x 1 3/4 " H x 7 1/4 " D
Weight	2.2 lbs.

GENERAL TRANSMITTER SPECIFICATIONS

Transmission Carrier	Infrared
Transmission Frequencies	IRH-35 2.08 MHz, 2.54 MHz IRH-40 2.30 MHz, 2.80 MHz
User Channel Switchable	Ch A or B (Crescent, Pendant, Body-Pack) Ch A or B IRT-35 Handheld Ch C or D IRT-40 Handheld Ten
Transmitting Diodes	FM Wide-Band
Modulation	32.768 KHz
Pilot Tone Frequency	± 25KHz
Peak Deviation	2500 Ft ² . 60 Ft. line of sight
Operating Range	On/Off
Power Switch (Slide)	Green, (Useable Charge)
Battery Charge Level (LED)	Red, (Needs Charging)
Battery Life	Approx. 7 Hr./Charge
External Battery Contact	Charger Connection

IRT-89 PENDANT TRANSMITTER

Adjustable Lanyard	Safety Breakaway Clasp
Transmission Angle	180°
Input	Top/Center
Microphone Input	3.5mm Jack, Lo-z
Waist Band Clip	Tension Wire
Dimensions	5.25" H x 1.5" W x 1" D
Weight	4.8 oz. w/ Batteries
LM-300	Plug-In Microphone
Mic Type	Electret/Condenser
Pick-Up Pattern	Unidirectional
Connector	Male, 3.5 mm
Frequency Response	100 Hz – 16 kHz
Windscreen	Pop Filter

IRB-30 BODY-PACK TRANSMITTER

Transmission Angle	180°
User Controls	Mic. Volume Power On/Off IR power Output: (Hi/Lo) Ch. Select (A or B)
External Mic. Input	Lo-z, 3.5mm
Waist Band Clip	Heavy Spring Wire
Dimensions	4 ³ / ₄ " H x 2 ³ / ₄ " W x ³ / ₄ " D
Weight	4.8 oz. (w/ batteries)

IRH-35 HANDHELD TRANSMITTER

Comander Circuit	Yes
Pre-emphasis	50μS
IR Emitter Location	Built-in
Transmission Angle	360°
Current Consumption	330ma
Microphone Element	Unidirectional, Dynamic
Battery	Two Rechargeable NiMH, 1.2v / 2300mAH
Battery Life	Approximately 6 – 8 Hours
Housing	Aluminum
Dimensions	10"Lx1 1/2" Dia.
Weight	11.4 oz. (with batteries)

IRH-40 HANDHELD TRANSMITTER

Comander Circuit	Yes
Pre-emphasis	50μS
IR Emitter Location	Built-in
Transmission Angle	360°
Current Consumption	330ma
Microphone Element	Unidirectional, Dynamic
Battery	Two Rechargeable NiMH, 1.2v / 2300mAH
Battery Life	Approximately 6 – 8 Hours
Housing	Aluminum
Dimensions	10"Lx1 1/2" Dia.
Weight	11.4 oz. (with batteries)

IRT-30 CRESCENT TRANSMITTER

Shape	Crescent, Under Chin
Lanyard Attachment	Snap-In, Top (Safety)
Transmission Angle	180°, Conical
Emitting Diodes	Six
Mute Switch	Momentary, On/Off
Aux. Input (3.5mm)	Switchable, Mic. or Line Level
Volume Control	Thumb, Rotary
Two Microphone Elements	Condenser Type, Unidirectional
Battery	Single "AA" NiMH, Rechargeable
Power Consumption	300 mA@1.2Volt
Battery Life	6-7 Hours
Battery LED	Green—Useable Red—Needs Charging
Dimensions	4¾" W x 1" D x 1¾" H
Weight	3.0 oz. w/ Battery

BRC-50 DROP-IN BATTERY CHARGER

Charging Slots	Two Handheld, Slots A & C One Crescent, Slot B One Body-Pack, Slot D
Charging Mode	Switching
Charging Current	1700ma ±10%
Discharge Rate	350ma
Red LED Indicator	Batteries being Charged
Green LED Indicator	Batteries Fully Charged
Yellow LED Indicator	Batteries being Discharged
Audible Alert	Intermittent Buzz - Batteries Fully Charged
Recycle Button (Grey)	Press for Full Discharge and Auto Recharge
Auto Switching	Switch from Discharge to Charge Mode
Charging Time	1.5Hr./Slot
Power Supply	12VDC/1.5A (Fuse protected)
Dimensions	6½" L x 3 3/8" W x 1 1/8" H
Weight	12.2 oz.

SINGLE-INSERT CHARGER (BRC-101)

Charging Port (Single)	Pendant or Handheld
Flashing Red LED	Batteries being charged
Solid Green LED	Batteries fully charged
Dimensions	5" W x 3¾" D x 1½" H
Weight	7.4 oz.

DUAL DROP-IN CHARGER (BRC-202)

Charging Ports (Two)	Pendant or Handheld
Flashing Red LED	Batteries being charged
Solid Green LED	Batteries fully charged
Dimensions	7½" W x 3¾" D x 1½" H
Weight	14.8 oz.

ICS-55 CEILING DOME SENSOR

Operating Frequency	2.00 MHz to 3.2 MHz
Number of IR LED's	Six with magnifying lens
Interconnection Cable	50Ft. Plenum Rated Dual Shielded Cable
Cable Connectors	RCA
Operating Range	50–60 Feet Line of Sight
Reception Area	2500 Ft. ²
Power Indicator	Green LED
Reception Angle	360° Semi-Spherical Coverage
Dimensions	5" D x 1½" H
Weight (with 50' cable)	1.2 lbs.

Five Year Limited Warranty

TeachLogic Infrared products are guaranteed to be free of defects in workmanship or material for a period of five (5) years from date of original purchase, subject to the following conditions:

1. Warranty excludes defects caused by normal use and wear, any abuse, or failure to use the product in accordance per instructions.
2. Warranty is void if damage occurred because of misuse, or attempted repair or modification by unauthorized personnel.
3. Warranty on batteries, cables, and cable connections are limited to one (1) year.
4. Warranty on microphones/microphone elements are limited to ninety (90) days.
5. Warranty does not extend to finish or appearance past ninety (90) days.
6. All warranty service will be provided by TeachLogic or authorized service center
7. Warranty is made to the original purchaser and may not be transferred another user.
8. Warranty service rendered will be on a repair basis or replacement, which ever TeachLogic deems to be most prudent for customer satisfaction and economic feasibility.

TeachLogic will only accept warranty shipments accompanied by Return Authorization Number previously assigned by TeachLogic personnel. Advance warranty replacements will be made per the discretion of TeachLogic personnel.

TeachLogic will pay return shipping cost on all warranty repairs or replacements.

For Warranty Service: TeachLogic, Inc.

Tel: (800) 588-0018 or (760) 631-7800

Customer Service Department

1688 Ord Way

Oceanside, CA 92056



TeachLogic, Inc.
1688 Ord Way
Oceanside, CA 92056

Ph: 1•800•588•0018
Fax: 1•760•631•1283
Email: sales@teachlogic.com
enet: www.teachlogic.com