

Titan

Owner's Manual



Portable Wireless UHF Sound System

INTRODUCTION

Notes

Date of Purchase: _____

Model Number: _____

Serial Number: _____

Notes:

INTRODUCTION

Thank You

Congratulations on the purchase of your new Titan Sound System. You can be assured that the Titan fulfills all specifications and was produced to very high quality control standards. TeachLogic incorporates the latest state of the art technology, employs the most advanced manufacturing methodology and uses only premium quality components to assure many years of reliable performance. We appreciate your confidence by your selection of our product. It is TeachLogic's intent to uphold that confidence by providing factory assistance and dealer support.

We hope you will take the time to view this manual to familiarize yourself with the product features and its operation. This manual will help you learn to use and gain the maximum benefit of the Titan system. The manual provides a basic explanation, followed by the system description and operating and instructions. The manual will conclude with maintenance, troubleshooting procedures and specifications.

Contact

If you should encounter some unresolved issue, please contact TeachLogic customer service department for further assistance.

☎ 1-800-588-0018

✉ sales@teachlogic.com

☎ 1-760-631-1283

🌐 www.teachlogic.com

Brian Van Waay

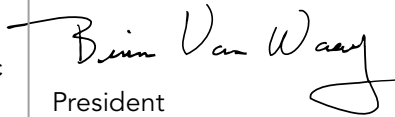

President

INTRODUCTION

Safety Instructions

Read Instructions

All safety and operation instructions should be read before operating this TeachLogic product.

Retain Instructions

Safety and operating instructions should be kept for future reference.

Water & Moisture

This product should not be operated near water or excessively moist area.

Heat Environment

Do not subject this product to excessive heat conditions.

Power Source

This product must be connected to an AC power source per the voltage input specified and marked on the power supply.

Power Cord Caution

Power cable should be routed clear of foot traffic and supported clear of kinking or abrasion.

Object Protection

Locate the operating unit so it will not be subjected to falling objects or water entry.

Proper Installation

Adhere to safe positioning to avoid falling, dismounting, head clearance, or cord cable obstruction

Internal Service

User should not attempt to service this product. A qualified technician must accomplish all internal service.

Electric Shock

Do not adapt or modify the AC power plug thus lifting the earth ground connection.



CAUTION

**RISK OF ELECTRIC SHOCK:
DO NOT OPEN**

Caution: To Reduce The Risk Of Electric Shock Do Not Remove Cover (Or Back)
No User-serviceable Parts Inside
Refer Servicing To Qualified Personnel

Certifications



Listed



TeachLogic systems are manufactured using lead-free processes and are free of materials harmful to the environment. They conform to the most stringent new European guidelines for consumer products (RoHS).

Caution

Recycle—Do not dispose of rechargeable batteries in trash. Actually it is unlawful to do so in CA, NY & ME.

Contact: Earth911.com
1-800-CLEANUP

Save our resources and don't contaminate.
Go Green

INTRODUCTION

Table of Contents

Introduction	i-7
Titan Components & Operation.....	8-25
Transmitter/Microphones	26-33
Battery Chargers	34-35
Troubleshooting	36-43
Accessories	44
Specifications	46-48
Warranty	49

INTRODUCTION

About RF Transmission

RF (radio frequency) wireless microphones have become commonplace use for the convenience of free movement with a microphone. Today's technology and advanced engineering has made the wireless microphone very reliable and render excellent vocal quality.

However, there are some inherent deficiencies that it is helpful to be aware of. RF is a radio signal being transmitted from the microphone to a receiver, like the radio transmitter transmitting to your radio. Note; whenever you are transmitting through space, you are always subject to interference by another transmitting source. This can show up as static, interruption (dropouts), or even complete blockage. To overcome interference, change the channel to a non-competing frequency. Just like when you drive near a powerline and you get a lot of static on your radio.

Another issue of awareness, RF can transmit in all directions and through solid surfaces for a distance of more than 100 feet. Therefore, what is said into the microphone will be transmitted and heard at all times unless the microphone is muted or turned off.

Wireless microphones are highly regulated by the FCC. There are frequency restrictions, power output limitation, and length of antenna.

The most troublesome problems occur as the result of low battery output. Typically, Alkaline batteries will provide 8–10 hours service and rechargeable batteries 6–8 hours.

INTRODUCTION

About the Titan

The Titan is a compact portable sound system for music playback or voice reinforcement housed in a rugged, lightweight cabinet. The basic system is comprised of a 50 watt power amplifier, control panel and battery power supply. The control panel provides input for either a balanced (XLR) or unbalanced (1/4" phone) microphone, dual line level input (RCA), and dual line level output (RCA). A unique feature of the Titan is the "Priority" function. When music is played through the system, the music level will be lowered 15 dB when you speak into the microphone and will automatically restored to normal level after speaking.

The internal batteries are rechargeable and will operate the system for 4–6 hours. Of course, the Titan can be plugged into an AC outlet for continuous operation while also charging batteries. Batteries will be fully recharged in 4–8 hours. Additional options can be added to the Titan. One or two wireless receivers (DR-760) can be installed for use with wireless microphones, (CD/MP-3) player to playback music and a wireless transmitter module (TX-750) to transmit the composite program to a companion Titan with a (DR-760) receiver.

The dual speaker system is comprised of an 8" woofer and a small high frequency horn to reproduce full range sound and efficient voice projection.

Measuring 12" wide, 9" deep, 18.5" high and weighing only 26.5 lbs., the Titan is very portable and practical for school events, sporting events, club outings, campaign speech or critical press conference.

TITAN COMPONENTS & OPERATION

Titan Rear

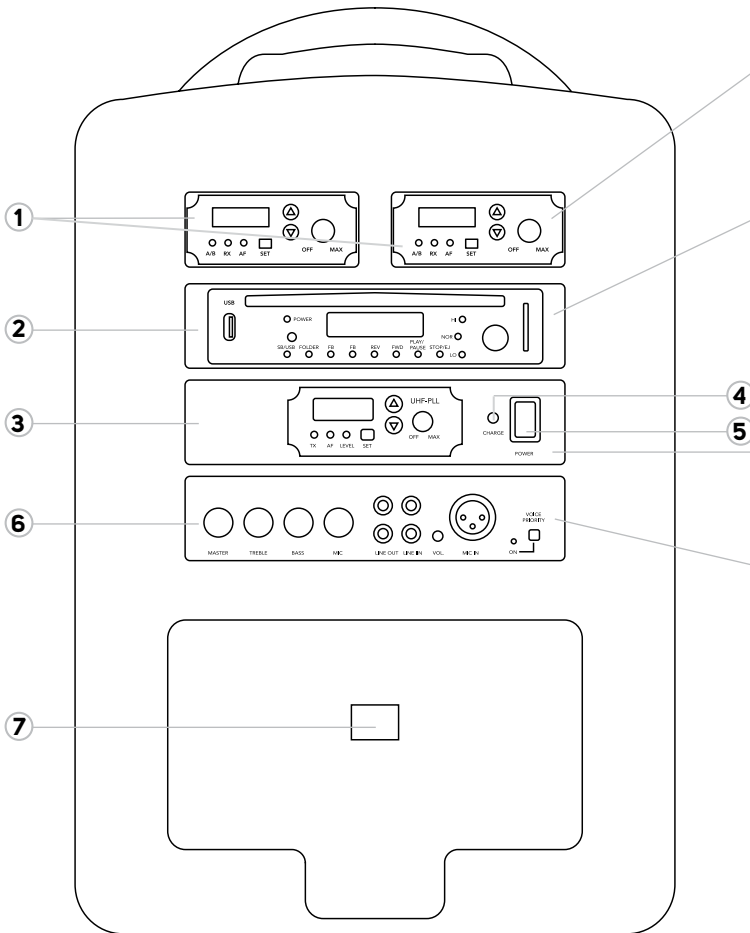

- 1 Optional DR-750 Receiver Modules
- 2 Optional CD/MP3 Player Module
- 3 Optional TX-750 Transmitter Module

- 4 Charge Indicator Light
- 5 Power Switch
- 6 Main Control Panel
- 7 110-240v AC Input

TITAN COMPONENTS & OPERATION**Receiver Module for Wireless Microphone Model: DR-750**

The Titan can be equipped with one or two wireless receiver modules for use with wireless microphones. Or as the receiver for the TX-750 transmitter thus serving the Titan as a wireless companion system. The receiver module has 96 selectable channels in the UHF range (640–664 MHz).

CD/MP3 Player Module with Remote Control Model: CD+MP3/R

In addition to being an anti shock CD / MP3 player it also features a USB Input Port and SD/MMC Reader. The pitch can be increased or decreased 10 levels up or down. Controls and functions include: Volume, Play/Pause, Stop/Eject, FWD, Rev, FF, FB and folder select. A fully functional remote control with Keypad provides remote operation of all functions.

AirLink Transmitter Module Model: TX-750

For larger venues or audiences, the TX-750 transmitter module will broadcast a composite program signal to companion units equipped with a DR-750 wireless receiver. The companion systems can be located throughout the venue without the need for speaker cables. The TX-750 will transmit all inputs including the wireless microphones, CD player, and control panel inputs. Typical operating range is 300–500 feet (line of sight).

Main Control Panel

The control panel provides the basic inputs and controls. Inputs include: Balanced (XLR) or Unbalanced (¼" phone) Lo-z microphone Input, Dual Line Input (RCA) with volume control, Dual Line Output (RCA), Mic. Volume Control, Treble & Bass Controls, and Master Volume Control.

Digital Time Delay Module Model: DD-750

(Optional for Companion System installed in place of TX-750)

The Digital Time Delay module receives the signal from the wireless receiver and stores the signal for a select time period and then it feeds its output to the remote sound system. The delay time can be selected in 20 millisecond increments from 20–500 milliseconds. The purpose for delaying the signal is to synchronize (time align) the sound output of the distant sound system with the master sound system.

TITAN COMPONENTS & OPERATION

Before Using the Titan

It is very important that you charge the batteries before attempting to use your Titan. Although the batteries were checked and fully charged prior to shipment, due to the shelf time and shipping time the batteries may have lost their full charge. Proper battery care will assure maximum performance and extended longevity.

Be sure to recharge batteries after every use and never store system with batteries in a discharged condition. It is a good practice to plug unit into an AC outlet while in storage, it will not damage or over charge the batteries and it will always be ready for use.

Lead Acid Batteries

Lead acid batteries provide maximum performance relative to their size, cost and weight. The expected service life is about 1½ years at a present day (6-1-10) price of \$107.00.

- Do not form a memory barrier
- Can be charged at any state of discharge
- Can be recharged hundreds of cycles
- Can be left plugged in continuously

Battery Care

Recharge soon after each use, if batteries not recharged within 72 hours after extensive use it will permanently damage the batteries.

Leave plugged in or recharge at least once per month.

Do not place in storage with batteries in discharged condition.

Evidence of battery approaching end of battery life:

- Less service per charge
- Distorted sound
- Will not accept charge

TITAN COMPONENTS & OPERATION

Main Control Panel

The main control panel is the basic panel for all Titans and Titan companions. It houses the power "on/off" switch and master volume control. It provides the hardwired microphone input, auxiliary input, record output, mic & line volume controls, tone controls and the unique "Voice Priority" switch.

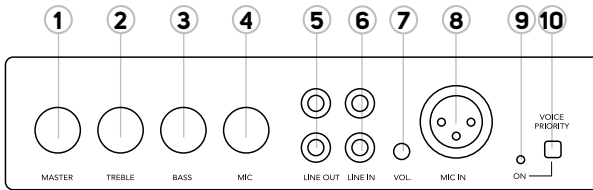

- | | |
|-----------------------------|---------------------------------|
| 1 Master Volume Control | 6 Dual Line Input (RCA) |
| 2 Treble Control | 7 Line Input Volume Control |
| 3 Bass Control | 8 XLR/¼" Phone Wired Mic. Input |
| 4 Wired Mic. Volume Control | 9 Priority Override Indicator |
| 5 Dual Line Output (RCA) | 10 Priority Override Switch |

Operation

1. Wired microphone input: (XLR) balanced
Lo-z (¼" phone) unbalanced Lo-z
2. Mic volume controls volume of wired microphone input
3. "Priority Switch" when pushed in: the volume of all program inputs will be reduced 15 dB when any microphone (wired or wireless) is spoken into. The volume of the program inputs will automatically restore to prior level upon completion of announcement
4. Dual line input jacks (RCA) provide input for stereo program source i.e. ipod, MP-3, CD player.
5. Separate line in volume control allows balancing auxiliary input with other inputs.
6. Dual line output is a composite output of all inputs; microphones (wired and wireless) and including the CD player
7. Individual base and treble tone controls allows adjustment for desired tone.
8. Master volume controls the composite volume of all the inputs

TITAN COMPONENTS & OPERATION

Power Panel

(Units without TX-750 AutoLink or DD-750 Digital Delay Module)

The basic power panel houses the master power switch with power indicator and charging LED.



- 1 Battery Charging Indicator Channel "Up/Down" Selector
- 2 System Power Switch

Operation

1. Push rocker switch to "on" position. Indicator in switch will illuminate steady "red".
2. If plugged into AC power, LED will glow "Green" if batteries are fully charged
3. If "red" indicator in switch flashes: Indicates batteries are getting low and unit should be turned "off" or plugged into AC power for continued use.
4. Plugged into AC power, the charging LED will glow "red" indicating batteries are being charged.
5. Once batteries are 80 – 90% charged, the charging LED will flash "red" and "green" until fully charged
6. Once fully charged, the charging LED will glow steady "green"
7. When plugged into AC power, the batteries will automatically get charged.

TITAN COMPONENTS & OPERATION

DR-750 Receiver for Wireless Microphone

One or Two receiver modules can be installed in the Titan. Each receiver has 96 selectable channels to assure interference-free operation and is equipped with a diversity antenna for added sensitivity.

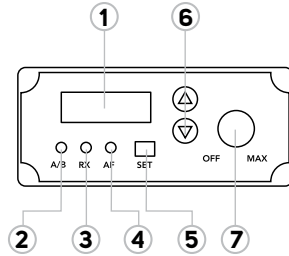

- | | |
|--|---|
| 1 LCD Display: Ch. # or Freq. Readout | 5 Channel Set: Lock/Unlock |
| 2 RF Reception: Diversity A/B Antenna | 6 Channel "Up/Down" Selector |
| 3 Transmission Signal Present Indicator (Yellow) | 7 Receiver Module: "on/off" and Master Gain |
| 4 Flash-Audio Level Being Received | |

Operation

1. Turn receiver "on", turning volume/power switch clockwise.
2. The LCD screen will display "ON" then revert to factory default channel or the channel last selected.
3. To select or change channel, press the "SET" button. LCD display will start flashing.
4. Using the UP/DOWN arrow buttons set the receiver to desired channel or match transmitter channel.
5. Press "SET" button and to lock in the channel selected.
6. Adjust volume to desired level.
7. Module is now ready to receive signal from a wireless microphone or AirLink transmitter.
8. When receiving a transmission signal, the A/B diversity antenna LED will illuminate "Red/Green"
9. RX indicator will illuminate "Yellow", indicating receipt of signal from transmitter.
10. AF indicator will flash "Green" when receiving an audio signal.

TITAN COMPONENTS & OPERATION

DR-750 Wireless Receiver Module

The portable PA system can be equipped with one or two UHF receiver modules. Each module features 96 selectable channels for interference-free operation with multiple microphones or PA systems.

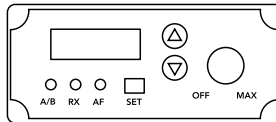

1. Turn the power switch/volume knob clockwise to turn the receiver unit on.
2. The LCD screen will display "ON" then revert to the factory default channel (or the channel last selected).
3. To select a channel press the "SET" button. Using the UP/DOWN frequency adjustment buttons you can set the receiver to match the channel used by the transmitter. Press the frequency set button again to lock in your channel selection.
4. Adjust the volume level to the desired position.
5. The module is now ready to receive signal from either a handheld, body-pack or AirLink transmitter. When receiving signal the A/B diversity indicator will illuminate red or green to show the diversity status. The RX indicator will illuminate yellow when signal from the transmitter is being received. The AF indicator displays audio level when users are speaking into the microphone.

TITAN COMPONENTS & OPERATION**CD-MP3R Player**

This anti-shock CD/MP3 player allows playback of both standard CD's and data CD's containing MP3 or WMA files.

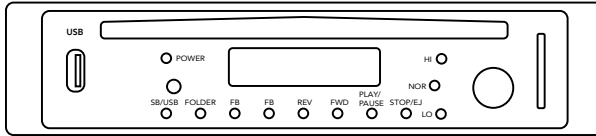

To operate, push the power button. Insert a CD into the CD slot and press play/pause button.

1. Adjust volume to desired level.
2. To skip forward a whole track press the next track button (>>|). To skip backwards a whole track, press the previous track button (|<<). To search through tracks, press and hold either of these buttons until you reach the desired point in the track.
3. Repeat allows repeating of single songs or all songs. Shuffle plays tracks in a random order.
4. To program specific tracks for playback press the track program button. Select the song you wish to program on the disc using the next track (>>|) and previous track buttons (|<<). Press repeat to enter the track into the program. Repeat as necessary. To playback programmed tracks press the play/pause button. Note: program will be reset whenever the track program button is pressed.
5. For use with MP3 discs you can select folders of music on the CD. Press the folder button and use the next track (>>|) and previous track buttons (|<<) to select your desired folder. Note: this function searches the disc in alphanumeric order.

TITAN COMPONENTS & OPERATION

CD-MP3R Player Functions

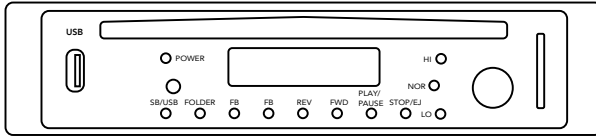

POWER

- **ON:** Press Power to switch on the power.
- **OFF:** Press and hold Power to switch off the power.

LCD DISPLAY Displays CD status including track number and playing time.

SD/USB/CD Press this key to change USB, SD or CD mode.

FB Select fast backward. Then press "PLAY/PAUSE" for normal playback.

FF Select fast forward. Then press "PLAY / PAUSE" for normal playback.

FOLDER Selects pre-programmed folders. Available when playing MP3 format files. Press FOLDER key again to advance to next folder.

REV Press to desired previous track number.

FWD Press to desired next track number.

PLAY/PAUSE Press once to play, press again to pause.

STOP/EJECT Press to stop playing, press again to eject disc.

Infrared window Picks up signal from the remote controller.

USB Connector Accepts USB Drive

SD Connector Accepts SD Card and MMC Card.

LO-PITCH To adjust slow-speed play. Press once, the screen will indicate PH-01, press again, the screen will indicate PH-02. There are 10 steps of speed variation.

HI-PITCH To adjust fast-speed play. Press once, the screen will indicate PH-01, press again, the screen will indicate PH 02. There are 10 steps of speed variation.

NOR-PITCH To adjust the speed to zero. Press NOR/PITCH key, the speed will be zero back to normal play.

TITAN COMPONENTS & OPERATION

CD-MP3R LCD Display

CD When in CD mode, the display panel shows "Cd".

USB When in USB mode, the display panel shows "USb".

SD When in SD mode, the display panel shows "Sd".

PLAY When in play mode, the display shows "▶".

PAUSE When paused, the display shows "||".

REPEAT When repeatedly playing the single track, it shows "REPEAT 1".

REPEAT ALL When all tracks are playing repeatedly, it shows "REPEAT ALL".

REPEAT FOLDER When all tracks in a specific folder are playing repeatedly, it shows "REPEAT FOLDER".

SHUFFLE Will playback Random tracks.

MEMORY When playback programmed tracks.

PROGRAM Will program tracks.

A→B Will continuously loop a track between selected point A and B.

□□ Under the MP3 mode, it will appear the folder numbers.

□□□ Display the current playing track.





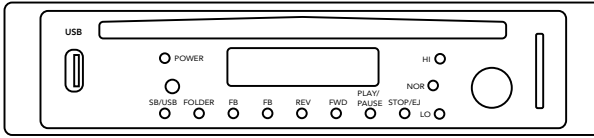

□□:□□ Display the time for the current playing track.

VOLUME Turn to adjust & control the desired volume.

TITAN COMPONENTS & OPERATION

Playing CD-MP3R

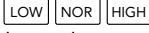

- This player will accept 4.75" (12 cm) discs like CD, CD-R, CD-RW, MP3, USB and SD / MMC memory cards, but will not play CD-ROM / CD-I / CDV, or 3" (8 cm) discs.
- The CD player will accept MPEG-3 (MP3) and WMA format files.
- Insert a disc into disc slot with the playback side down, playback starts automatically. Track number and playing time will be displayed.
- To pause playback or start normal playback, press PLAY/PAUSE or press  on the remote controller.
- Press REV, F.WD, or  on the remote controller, to select previous or next track. CD player will continue playback while displaying selected track.
- To stop playback, press STOP/EJECT or press  once on the remote controller.
- To eject CD press STOP/EJECT once to stop playback. Press again to eject CD. Or press  on remote controller.
- Press FB, FF or  on the remote controller, to activate fast back or fast forward until desired selection is located.
- Press LO, NOR, HI/PITCH or  on the remote controller to adjust low, normal and high playback pitch.
- Press FOLDER or  on the remote controller, will select the next catalogue of tracks to be played.

Note

When inserting or removing a disk into CD player, do not push or pull the disk by hand. Let the CD player pull the disk in and or return disc automatically. Pushing or removing the disk by hand will damage the machine and cause it not to operate normally.

TITAN COMPONENTS & OPERATION

Playing SD/MMC Card

- Insert SD Card or MMC Card into the insert hole of SD/MMC CARD in the face plate. Push the card into the SD/MMC card slot. To remove the card, please push the card to the bottom and then release. Please do not use force to pull card out. Pulling the card will damage the card and/or machine.
- Press SD/USB/CD or SD/USB/CD on the remote controller. Select SD then press PLAY/PAUSE or  on the remote controller to play.

Playing USB Drive

- Insert USB into the insert hole of USB in the face plate.
- Press SD/USB/CD or SD/USB/CD on the remote controller.
- Select USB then press PLAY/PAUSE or  on the remote controller to play.







TITAN COMPONENTS & OPERATION



Remote Controller Functions





EJECT Press  to stop playing and eject the disc.

 can memorize a set of tracks for playback.

To Program a set of tracks:

- 1) Insert a disk into the CD player, press  key one time.
- 2) Enter the folder and track number then press  to confirm selection.
For example: To program track 23 then 42 then 19, Press 0 and 1 for folder, the LCD will display "01". Then press 2 and 3 for track number, the LCD will display "23". Then press  to confirm selection, the LCD will display "01 23:01". This is Folder number 1, track number 23, first selection to play.
Then press 4 and 2 for track number, the LCD will display "42 :02" for track number and selection number 2. Then press  to confirm selection, the LCD will display "01 42:02".
This is Folder number 1, track number 42, second selection to play.
Then press 1 and 9 for track number, the LCD will display "19 :03" for track number and selection number 3. Then press  to confirm selection, the LCD will display "01 19:03".
This is Folder number 1, track number 19, third selection to play.
- 3) Repeat this process until all desired tracks have been memorized.
- 4) When all selections have been memorized press .

 A random selection of tracks will play. Press  and the LCD will display "SHUFFLE".

 **REPEAT MODE.** While playing a CD, press  once, the LCD will display "REPEAT ALL". Repeat All will repeat all tracks one time. Press  again, the LCD will display "REPEAT 1". Repeat 1 will repeat all songs in that folder. Press  a third time, all repeats will be cancelled.

TITAN COMPONENTS & OPERATION

Remote Controller Functions

Note

When using the remote control, the remote should be pointed toward the face plate of the CD/MP3 Player. The optimal receiving distance is 10 feet.

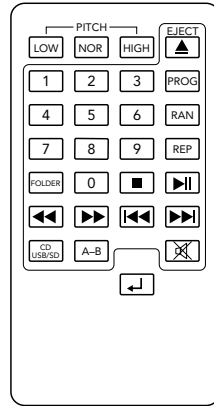

Replacing Remote Battery

1. Pull battery clip
2. Insert battery
3. Replace clip

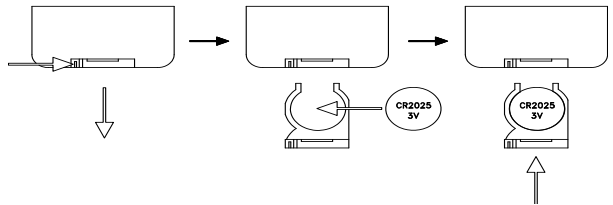

The battery for the remote is (model CR2025 3V).

TITAN COMPONENTS & OPERATION

TX-750 Transmitter Module

For larger venues or audiences, the addition of this module allows several units to be used in the same area without the need for speaker or signal wiring. In this application you have a master and as many slave units as required for the venue. The wireless AirLink module is installed in the master unit, which then transmits any audio signal (including wireless mic, CD player or wired mic) to the slave units, which are fitted with a UHF wireless receiver.

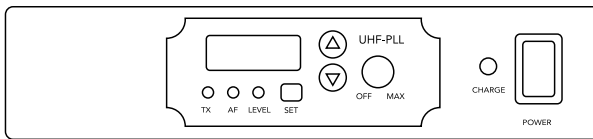

1. On the AirLink unit turn the power switch/volume level control clockwise to turn the transmitter on.
2. The LCD screen will display "ON" then revert to the factory default channel (or the channel last selected).
3. To select a channel press the "SET" button. Using the UP/DOWN frequency adjustment buttons you can select the desired channel. Press set again to lock-in channel.
4. On the slave unit turn the wireless receiver module on. Press "SET" and use the UP/DOWN frequency adjustment buttons to set the unit to the same channel as the master unit. Press the frequency set button again to lock in your channel selection.
5. When transmitting audio from the master to slave unit the TX indicator will light green. The AF indicator displays audio level (flashing red) when user is speaking into the microphone or music is playing.

TITAN COMPONENTS & OPERATION

Main Control Panel

Master volume adjusts overall system level from all inputs (i.e.: UHF, CD/MP3 player, RCA stereo input and wired microphones). Treble and bass controls affect all system inputs, when set to half way sound output will be flat.

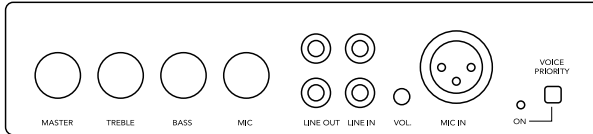

- Mic Input: XLR or ¼" phone jack for wired microphones. Volume of this input is controlled by Mic. and the Master controls
- RCA stereo jacks are provided for an external audio source. This allows connection of a CD player, iPod or other audio source. The volume of the Line In is controlled solely by the Master.
- RCA output is provided for use with external zone amplifiers or other PA systems if required or for sending the entire mix signal to other audio devices, such as recorders, mixers, or power amps. This output signal is combined from all inputs (i.e., UHF, CD/MP3 player, RCA stereo input and wired microphones).
- Microphone Priority Override when turned "on" program volume will immediately lower 15dB when microphone is spoken into and volume rise upon completion of announcement.

TITAN COMPONENTS & OPERATION

Companion Speaker

The PA-710 is an AC or battery powered Companion System with a 96 Channel Wireless Receiver for a wireless connection from a Titan Sound System with the TX-750 Wireless Transmitter installed.

The PA-710 can also be utilized as a self contained battery powered PA system with the use of a hardwired handheld microphone (UM-66), or wireless microphone (UT-96HH or UT-96BP).

With the addition of the DD-750 Digital Delay Module, the system becomes PA-715.

DD-750 Digital Delay Module

The Digital Delay Module DD-750 is installed in the companion speaker and is interfaced with DR-750 wireless receiver module. The output of the receiver is passed through the delay module in route to the power amplifier. The purpose of the delay module is to store the signal momentarily and then pass it through to the amplifier input. The delay time can be varied from 20–500 milliseconds thus synchronizing the sound output with the master unit on stage.

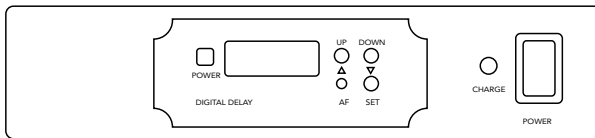

Time Delay Calculation

The true measurement of sound travel is 1125 feet per second. Thus sound travels at the rate of 1.125 feet per millisecond (ms). So the general rule is to round up to 1 foot per ms.

So to calculate the sound delay time from the main sound source to the distant speaker is to pace the distance in feet. Then dial the foot count into the digital delay module in milliseconds (ms). Example, if you were to pace off 150 feet, you would dial the digital delay to 150 ms. Now this approximate setting could be fine tuned by ear for a more exact setting.

□

TITAN COMPONENTS & OPERATION

To Set The Time Delay

Depress the power switch. The LCD screen will display the last saved delay time. To change the delay time select the "SET" button. Using the UP/DOWN time delay adjustment buttons, set the delay to the desired time in milliseconds. Press the "SET" button to lock in your delay time.

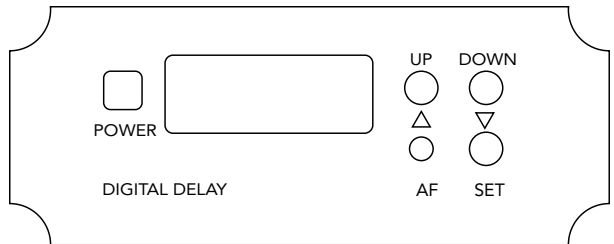

Note

Display times are available in 1.9 ms. increments.

TRANSMITTER/MICROPHONES

UT-96HH Transmitter Microphone Description

The handheld microphone/transmitter is equipped with a dynamic microphone element for enhanced clarity and extended dynamic range. Its low handling noise and built-in windscreen makes it well suited for close-up handheld use. It can be powered by either Alkaline or rechargeable NiMH batteries. The rechargeable batteries can be recharged either in the drop-in charger or with the plug-in charger.

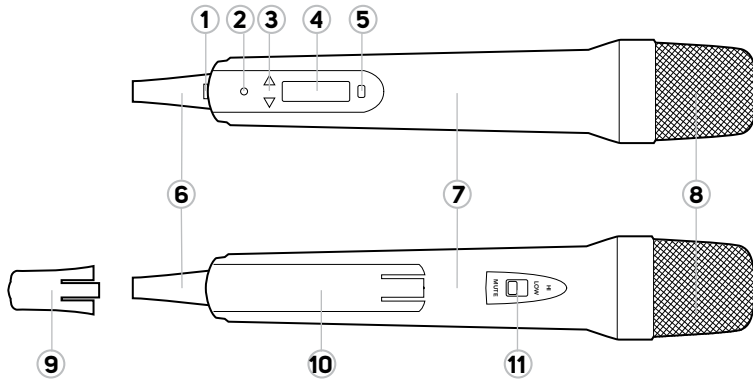

- | | |
|----------------------------|--|
| 1 Power "on/off" Switch | 7 Soft Comfort, Non-Slip Body |
| 2 LED Power "on" Indicator | 8 Protective Screen Head |
| 3 Up/Down Frequency Select | 9 Color Identity End Cap |
| 4 LCD Readout | 10 Battery Compartment |
| 5 Frequency Set Button | 11 Microphone Sensitivity:
HI/LOW/MUTE Select |
| 6 Charging Port Connection | |

TRANSMITTER/MICROPHONES

UT-96HH Transmitter Microphone Operation

1. Be sure the microphone is switched off before inserting batteries.
2. Remove lower identity cap.
3. Remove lower battery compartment door.
4. Insert two (2) AA batteries (use only alkaline or fully charged NiMH batteries).

Caution: Be sure to observe correct polarity

5. Replace lower battery compartment door.
6. Locate power switch at base of microphone (small gray button)
7. Press upward and hold the power switch for 2-3 seconds.
8. Power LED will illuminate "Red" and "On" will be displayed in the LCD screen.
9. LCD window will also display: Battery condition and CH #
10. A microphone sensitivity selection switch provides three modes of microphone sensitivity (HIGH, LOW, MUTE).
 - MUTE: Mutes microphone "off" while retaining transmission and RF connection.
 - LOW: Use when microphone is held close to mouth or strong vocal input.
 - HIGH: Use when additional sensitivity is required for softer voice.
11. LCD screen displays the channel number selected for the microphone. To display channel frequency: Press and hold the UP or DOWN select button.
12. To change channel selection
 - Press and hold frequency SET button for 2 seconds. LCD panel will commence flashing (indicating programming mode)
 - Press UP or DOWN arrow to select channel desired
 - Press SET button to lock in channel selected



Danger

**DO NOT ATTEMPT TO
CHARGE ALKALINE
BATTERIES**

TRANSMITTER/MICROPHONES

UT-96HH Transmitter Microphone Operation

13. The battery status is displayed on the left of the LCD screen.
 - When battery nears depletion: Icon will flash 3 times.
 - Microphone will automatically turn "off" to prevent damage.
14. To turn microphone "off", press and hold the power switch until the LCD screen displays "OFF".

FCC Regulation

RF transmission equipment must comply with FCC regulations. All TeachLogic transmission devices comply with Part 15 of the FCC rules and operate in the UHF band in the 640–664 MHz frequency range. Power output is limited to less than 50 milliwatts to prevent any interference with any other RF operated equipment.

TRANSMITTER/MICROPHONES

Titan UT-96BP Body-Pack Transmitter Description

The Body-Pack Transmitter is the component that transmits the voice to the Titan receiver. The audio is transmitted via an RF signal on a selected RF frequency. An external microphone is plugged into the Body-Pack Transmitter which picks up the speaker's voice. The microphone can be either a Lapel, Collar style or a Headset with a boom microphone. The transmitter is usually worn on the waist utilizing the wire belt clip, however; it can be placed in your pocket if it is more convenient. The Body-Pack is battery powered and requires two "AA" size batteries.

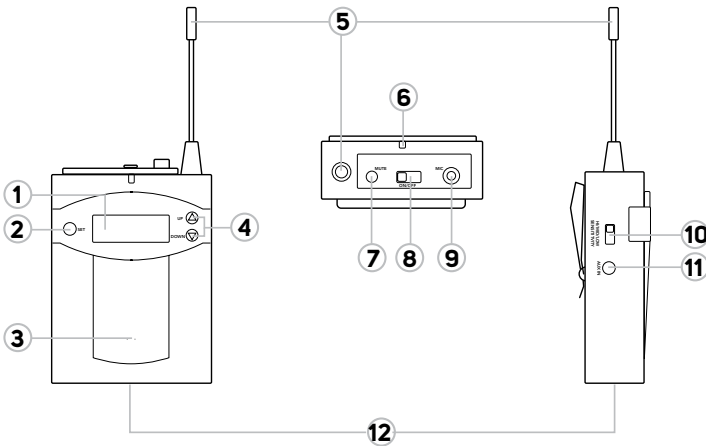

- | | |
|--|--|
| 1 LCD Display | 8 Power "ON/OFF" Switch |
| 2 Frequency SET Button | 9 MIC Input Jack (3.5mm)
Microphone Input Sensitivity Selection |
| 3 Built-In Microphone for Handheld Use | 10 Switch (L,M,H) |
| 4 UP/DOWN Ch. Select Buttons | 11 AUX Input Jack (3.5mm) |
| 5 Transmitting Antenna | 12 Charging Terminal |
| 6 Power "On" LED Indicator | |
| 7 Microphone Mute Button | |

TRANSMITTER/MICROPHONES

UT-96BP Body-Pack Transmitter Operation

1. Ensure microphone is switched off before inserting batteries.
2. Remove battery compartment cover.
3. Insert two "AA" batteries, observing polarity (alkaline or rechargeable NiMH).
4. Plug in microphone: Lapel, Headset w/boom, Collar or UltraLite mic.
5. Push power switch to "ON". Top power LED will illuminate "Red"
6. "On" will be displayed in the LCD screen.
7. LCD window will display: Battery condition and CH #
8. A selection switch on the side of the body-pack provides three levels of microphone sensitivity (HI/MID/LOW)
 - High: Most sensitive position for weak voice or distant microphone to mouth.
 - Mid: When the microphone used is further away from mouth, such as: a collar or lapel microphone is clipped on clothing away from mouth
 - Low: When microphone is used close to mouth, such as; a headset with a boom microphone or with a very strong vocal performer.
9. MUTE Button: Mutes microphone "off" while retaining transmission and RF Connection
10. Internal Microphone:
 - Locate two small hole on front of transmitter
 - Hold transmitter in front of mouth and speak into it.
11. LCD screen displays the transmission channel number and battery condition
12. To display channel frequency: Press and hold UP or DOWN button.



Danger

DO NOT ATTEMPT TO
CHARGE ALKALINE
BATTERIES

TRANSMITTER/MICROPHONES

UT-96BP Body-Pack Transmitter Operation

13. To change channel selection
 - Press and hold frequency SET button for 2 seconds
 - LCD panel will commence flashing (indicating programming mode)
 - Press UP or DOWN arrow to select channel desired
 - Press SET button to lock in channel selected
14. The battery status is displayed on the left edge of the LCD screen.
 - When battery nears depletion: Icon will flash 3 times
 - Transmitter will automatically turn "off" to prevent damage
15. To turn microphone "Off"; push power switch to "OFF".

FCC Regulation

RF transmission equipment must comply with FCC regulations. All TeachLogic transmission devices comply with Part 15 of the FCC rules and operate in the UHF band in the 640–664 MHz frequency range. Power output is limited to less than 50 milliwatts to prevent any interference with any other RF operated equipment.

TRANSMITTER/MICROPHONES

Optional Microphones for Body-Pack Transmitter

Any of the microphones below may be used with the Body-Pack Transmitter.

LM-835 Lapel Microphone

The Lapel Microphone (LM-835) is a small capsule microphone with a spring clip for securing it on to a clothing edge. The lapel microphone renders excellent vocal reproduction. The lapel microphone is less obtrusive to the user and least visible. However, due to the greater distance from mouth to microphone it will require additional gain. As a result it is more prone to feedback. So adjustment of volume is more critical, especially near or under a speaker.



HBM-935 Headband Microphone

The Headband Microphone (HBM-935) is worn around the head with a unidirectional microphone located on the end of a flexible boom. This is the best performing microphone due to its unidirectional mic element and its always close proximity to the mouth. The microphone also renders maximum gain and is least prone to feedback.



CM-835 Collar Microphone

The Collar Microphone (CM-835) is a flexible rod that can be formed to fit around the neck. The end with the microphone is then contoured up toward the mouth. The cord exits the flexible rod from the back, out of the way. The collar microphone utilizes a unidirectional element for excellent voice reproduction and minimizes feedback.



TRANSMITTER/MICROPHONES

Optional Microphones for Body-Pack Transmitter



ULM-835 Ultra-Lite Microphone

The Ultra-Lite Microphone (ULM-835) is a miniature boom style microphone supported by a wire around the left ear. The unidirectional microphone element renders excellent vocal quality and maximum clarity. Its lightweight and miniature size make it comfortable and inconspicuous. It is available in either beige or black.

Caution

The Ultra-Lite boom can be formed to fit but it is not considered to be flexible. So it cannot be bent back and forth; IT WILL BREAK!



LM-300 Plug-In Microphone w/ Lanyard

The Plug-in Microphone (LM-300) is a small capsule size microphone that plugs directly into the top of the Body-Pack. With the adjustable lanyard, the Body-Pack can be worn around the neck as a pendant style microphone. The Body-Pack is easily removed from the lanyard to facilitate use as a handheld microphone.

BATTERY CHARGERS

BRC-10 Plug-In Charger

The BRC-10 charger is designed to charge the UT-96HH Handheld Transmitter/Microphone.

Operating Instructions

- Use "AA" rechargeable NiMH batteries only
- Plug adapter into 110v AC outlet.
- Remove color identification cap.
- Plug cable into jack at the base (bottom end) of transmitter
- Turn Handheld Transmitter "On" to observe battery icon
- During charging, the battery icon will cycle through the charge "block"
- When fully charged, battery icon will display all "blocks" filled
- Charging time; typically 10–12 hours
- Turn Handheld Transmitter "Off" and reinstall color identification cap.



BRC-75 Drop-In Charging Dock

The BRC-75 charger is designed to charge one or two UT-96BP Body-Pack Transmitters.

Operating Instructions

- Use "AA" rechargeable NiMH batteries only in microphones
- Plug power adapter in 110v AC outlet
- Plug cable into base of charger
- Insert one or two body-pack transmitters into charger
- "on" indicator LED lights "Amber" when charging
- "ok" indicator LED lights "Green" when fully charged
- Charging time; typically 10–12 hours



BATTERY CHARGERS

BRC-70 Drop-In Charging Dock

The BRC-70 charger is designed to charge the UT-96HH and/or UT-96BP Body-Pack Transmitter.



Operating Instructions

- Use "AA" rechargeable NiMH batteries only in microphones
- Plug power adapter in 110v AC outlet.
- Plug cable into base of charger
- Charging Handheld Microphone/Transmitter
 - Remove color identification cap from Hand held microphone, store on cap holder
 - Insert Handheld microphone into small square receptacle
 - Push down firmly in place
- Charging Handheld Indicators (Handheld symbol)
 - "on" indicator LED lights "Amber" when charging
 - "ok" indicator LED lights "Green" when fully charged
- Charging Body-Pack Transmitter
 - Insert Body-Pack into Front/Large receptacle
 - Push down firmly in place
 - Observe front with LCD facing forward (toward you)
- Charging Body-Pack Indicators (Body-Pack symbol)
 - "on" indicator LED lights "Amber" when charging
 - "ok" indicator LED lights "Green" when fully charged
- Charging time; typically 10–12 hours.
- During normal charging the battery icon will cycle through the charge "block" icons
- Remove transmitters when charging is complete
- Reinstall color identification cap on handheld
- Turn transmitter "On", verify battery icon in LCD window shows all blocks filled



TROUBLESHOOTING

UT-96HH Transmitter Microphone

Problem	Solution
Power LED does not illuminate after pressing power switch	<ul style="list-style-type: none">• Check batteries are charged and inserted correctly. When pressing power switch ensure you hold it down for 2–3 seconds
LCD panel displays garbled information	<ul style="list-style-type: none">• Remove the batteries from the transmitter and re-insert them
No sound output	<ul style="list-style-type: none">• Confirm frequency of transmitter is the same as the portable PA receiver• Check volume level of both transmitter and portable PA receiver in range of the receiver• Check for sources of interference, large metal objects etc within range of the microphone

Contact

If you should encounter some unresolved issue, please contact TeachLogic customer service department for further assistance.

 1-800-588-0018

 sales@teachlogic.com

 1-760-631-1283

 www.teachlogic.com

TROUBLESHOOTING

UT-96HH Transmitter Microphone

Problem	Solution
Interference and Signal disturbance	<ul style="list-style-type: none"><li data-bbox="625 323 975 540">• Make sure there are no other wireless systems operating on the same frequency in the same area. This includes Microphones, Televisions, Radio Stations, etc.<li data-bbox="625 548 975 732">• When operating two transmitters in the same area, ensure frequencies selected are several channels apart. This helps to reduce cross-talk between transmitters.<li data-bbox="625 740 975 891">• Also note that other wireless devices can cause interference, ensure you adjust your frequency around these devices where possible.<li data-bbox="625 899 975 987">• Try setting the transmitter and receiver to a new channel

TROUBLESHOOTING

UT-96BP Body-Pack Transmitter Microphone

Problem	Solution
Power LED does not illuminate after switching on	<ul style="list-style-type: none">• Check batteries are charged and inserted correctly.
LCD panel displays garbled information	<ul style="list-style-type: none">• Check frequency of transmitter is the same as the portable PA receiver• Check mute button is not activated• Ensure body-pack is within range of the receiver• Check for sources of interference, large metal objects etc within range of the body-pack
Signal disturbance	<ul style="list-style-type: none">• When operating two transmitters in the same area, ensure frequencies selected are several channels apart. This helps to reduce crosstalk between transmitters. Also note that other wireless devices can cause interference, ensure you adjust your frequency around these devices where possible.

ERR Message

The ERR message may show up on the units ALS-960, DR-702, DR-702D, DR-750, TX-750 and UT-96BP or UT-96HH. In brief, any wireless-based devices that carry a LCD panel might have this potential problem. While the possibility of a glitch is unlikely, it is a possible.

Contact

If you should encounter some unresolved issue, please contact TeachLogic customer service department for further assistance.

☎ 1-800-588-0018

✉ sales@teachlogic.com

☎ 1-760-631-1283

🌐 www.teachlogic.com

Sorting out LCD ERR message

The ERR message may show up on the units UT-96HH, UT-96BP, DR-750 and TX-750. In brief, any wireless based devices that carry a LCD panel might have this potential problem. The feasibility of such kind of rick shall be quite few, but it might occur. Following I will give you a instructions to kill this problem. LCD panel works "normally" when shown as below...



"On" shown on the LCD panel when unit was switched on.



In 1–2 seconds, the LCD panel will show channel number that was used last time on the LCD panel.



Generally, there are two possibilities that bring "Error" message to the devices, software or hardware problem. Following instructions will lead you to sort out problems caused by software.

1. RESET built in software by pressing and holding "SET" + "UP" + "DOWN" then Switch unit on.
2. How to know if the RESET is done successfully? "On" message will be shown on the LCD panel and it will stay on "On" message—it won't display the channel last used.
3. When you've successfully cleared the "ERR" message, switch the unit off, then on. Now use the transmitter normally.



Channel Selection in a Given Area and Simultaneous Use of Multiple Channels.

Transmission by wireless microphones and low power audio transmitters may encounter various interference problems. Interference may be caused by local area TV or commercial broadcast institutions.

In addition, interference can be due to wireless receivers and transmitters used simultaneously in close proximity to each other. Their fundamental or harmonic frequencies can conflict with each other and cause interference problems; noises, static, hiss, dropouts, squealing or totally inoperative.

The following clusters of channels have been designated that are compatible to operate with each other simultaneously.

Clusters of Compatible Frequencies when using Four (4) channels at the same time

- (1) 19 20 35 36 (2) 10 57 58 59 (3) 19 34 36 39
 (4) 20 35 39 69 (5) 57 75 77 90 (6) 11 44 45 57
 (7) 07 53 84 87

Clusters of Compatible Frequencies when using Eight (8) channels at the same time

- (1) 06 39 42 45 55 70 89 90
 (2) 17 18 20 33 34 36 37 89
 (3) 01 02 06 37 49 50 70 84
 (4) 02 49 50 52 68 69 71 86
 (5) 34 40 52 57 68 69 81 82

Note

When interference problem is encountered, verify that the microphones are operating on frequencies in the same cluster.

If TV or other transmission is interfering, change all the wireless components to another cluster.

Clusters of Compatible Frequencies when using Twelve (12) channels at the same time

- (1) 20 21 49 50 58 65 66 71 75 85 85 87
 (2) 02 17 21 22 25 26 41 42 67 82 85 86

TROUBLESHOOTING**Channel Frequency Allocation****640–664 MHz LCD**

CHANNEL	FREQ	CHANNEL	FREQ	CHANNEL	FREQ
CH 1	640.1	CH 17	640.9	CH 33	640.4
CH 2	641.6	CH 18	642.4	CH 34	641.9
CH 3	643.1	CH 19	643.8	CH 35	643.3
CH 4	644.5	CH 20	645.3	CH 36	644.8
CH 5	646.1	CH 21	646.9	CH 37	646.4
CH 6	647.6	CH 22	648.4	CH 38	647.9
CH 7	649.1	CH 23	649.8	CH 39	649.3
CH 8	650.5	CH 24	651.3	CH 40	650.8
CH 9	651.7	CH 25	652.6	CH 41	652.1
CH 10	653.3	CH 26	654.1	CH 42	653.6
CH 11	655.2	CH 27	656.0	CH 43	655.5
CH 12	656.7	CH 28	657.5	CH 44	657.0
CH 13	658.2	CH 29	658.9	CH 45	658.4
CH 14	659.6	CH 30	660.4	CH 46	659.9
CH 15	661.2	CH 31	662.0	CH 47	661.5
CH 16	662.7	CH 32	663.4	CH 48	662.9

UHF TV Frequencies

TV Channel	MHz
42	638–644
43	644–650
44	650–656
45	656–662
46	662–668

TROUBLESHOOTING

CHANNEL	FREQ	CHANNEL	FREQ	CHANNEL	FREQ
CH 49	641.1	CH 65	640.6	CH 81	641.4
CH 50	642.6	CH 66	642.1	CH 82	642.9
CH 51	644.0	CH 67	643.5	CH 83	644.3
CH 52	645.5	CH 68	645.0	CH 84	645.8
CH 53	647.1	CH 69	646.6	CH 85	647.4
CH 54	648.6	CH 70	648.1	CH 86	648.9
CH 55	650.0	CH 71	649.5	CH 87	650.3
CH 56	651.5	CH 72	651.0	CH 88	651.9
CH 57	652.8	CH 73	652.3	CH 89	653.1
CH 58	654.3	CH 74	653.8	CH 90	654.6
CH 59	656.2	CH 75	655.7	CH 91	656.5
CH 60	657.7	CH 76	657.2	CH 92	658.0
CH 61	659.1	CH 77	658.6	CH 93	659.4
CH 62	660.6	CH 78	660.1	CH 94	660.9
CH 63	662.2	CH 79	661.7	CH 95	662.5
CH 64	663.6	CH 80	663.1	CH 96	663.9

ACCESSORIES

ALS-960 AirLink Wireless and DR-701 Receiver

The ALS-960 transmitter and DR-701 receiver work perfectly with our Titan portable powered sound system.



SP-300W Spartan Portable Amplifier



The Spartan is a portable battery/AC operated sound system with 20 watt (RMS) amplifier. Weighing only 6 pounds it's packed with versatile features: USB port for MP3 playback, 3.5mm jack for auxiliary line input, 96 channel wireless receiver, 1/4" wired mic input and output jack for external speaker.

UM-66 handheld microphone w/ 15' cable

Handheld dynamic microphone for simultaneous use with the wireless microphones. The 1/4" phone plug plugs directly into the mic in jack. The wired mic in has its own independent volume control. So you can truly have a three microphone system. The microphone has very low handling noise, a built-in breath filter and wide dynamic range.



CC-750 Carrying Bag for Titan

Carrying case holds PA-700 speaker with opening for handle & side storage pocket for transmitters, etc.

SS-750 Heavy Duty Speaker Stand

Heavy duty speaker stand for Titan sound system. Folding tripod adjustable height from 30" to 60".



HT-175 Mini Mover Handtruck

Superlite folding hand truck. The Mini Mover has three vertical handle positions and the wheels and baseplate fold flat for easy storage. Folds down to only 2" x 15.25" x 24". 110 lbs. load capacity and 5" wheels. Only 7.25 lbs.

SPECIFICATIONS

Portable PA System

Power Output	50 Watts
Max SPL	108 dB
Frequency Response	70Hz–20kHz
Speaker	8" woofer/1" horn
S/N Ratio	70 dB
Sensitivity	91dB @ 1 watt/1 meter
Audio Input	Mic-XLR w/Volume Control Line/RCA w/Volume Control Master Volume Control
Audio Output	Line-RCA, Speaker ¼"
E.Q.	Bass, Treble
Battery	2-12V/2.9 AH Lead Acid
Battery Charging	4 hours
Battery Life	4-6 hours
Power Requirements	100–240VAC 50/60Hz Switching Power Supply
Speaker	Stand Mountable
Dimensions	12" x 9" x 18.5"
Weight	26.5 lbs.

General Wireless Systems

Operating Frequencies	640–664MHz
Selectable Channels	96 Pre-Programmed
Maximum Deviation	80 kHz, with Level Limiting
Dynamic Range	110dB
THD	> 0.5%
Pre/De-emphasis	50 µs
Sensitivity	4 µV@ 30 dB SINAD
Squelch	Tone Key and Noise Lock
Frequency Response	50 kHz, -17 kHz, ± 3dB
Operating Power	30 mW
Operating Range	In Excess of 500 ft. with Half-Wave Antenna
Power Requirements	12–15 VDC, 1 Amp

SPECIFICATIONS

DR-750 Wireless Receiver

Dimensions	3 ½" W x 1.5" H x 5" D
Weight	4 oz.

TX-750 Wireless Transmitter

Dimensions	7 ½" W x 1 3/16" H x 4" D
Weight	10 oz.

CD/MP3R Player

Formats	MP3, WMA
Media	CD, USB drive, SD&MMC card

DD-750 Digital Delay

Delay Range	20–500 ms.
Increments	1.9 ms.

SPECIFICATIONS

UT-96HH Handheld Transmitter Microphone

Mic Capsule	Dynamic
RF Output	10mW
Spurious Emission	250mW
AF Controls	Hi/lo/mute switch
Battery	1.2V NiMH rechargeable x 2 or 1.5V Alkaline x 2
Operating Life (fully charged)	11 hrs (NiMH) or 14 hrs (Alkaline)
Dimensions	1.80" x 10.39"
Weight (with batteries)	280g

UT-96BP Body-Pack Transmitter Microphone

Mic Capsule	Dynamic
RF Output	10mW
Spurious Emission	250mW
AF Controls	Hi/lo/mute switch
Battery	1.2V NiMH rechargeable x 2 or 1.5V Alkaline x 2
Operating Life (fully charged)	11 hrs (NiMH) or 14 hrs (Alkaline)
Dimensions	1.80" x 10.39"
Weight (with batteries)	280g

WARRANTY

Three Year Limited Warranty

TeachLogic RF products are guaranteed to be free of defects in workmanship or material for a period of three (3) years from date of original purchase, subject to the following conditions:

1. Warranty excludes defects caused by normal use and wear, any abuse, or failure to use the product in accordance per instructions.
2. Warranty is void if damage occurred because of misuse, or attempted repair or modification by unauthorized personnel.
3. Warranty on cables, and cable connections are limited to one (1) year.
4. Warranty on batteries is for ninety (90) days.
5. Warranty on microphones and microphone elements are limited to one (1) year.
6. Warranty does not extend to finish or appearance past ninety (90) days.
7. All warranty service will be provided by TeachLogic or authorized service center
8. Warranty is made to the original purchaser and may not be transferred to another user.
9. Warranty service rendered will be on a repair or replacement basis, whichever TeachLogic deems to be most prudent for customer satisfaction and economic feasibility.

Contact

If you should encounter some unresolved issue, please contact TeachLogic customer service department for further assistance.

 1-800-588-0018

 sales@teachlogic.com

 1-760-631-1283

 www.teachlogic.com

TeachLogic will only accept warranty shipments accompanied by Return Authorization Number previously assigned by TeachLogic personnel. Advance warranty replacements will be made per the discretion of TeachLogic personnel.

TeachLogic will pay return shipping cost on all warranty repairs or replacements.

TeachLogic

FOR SOUND LEARNING 

TeachLogic, Inc.
1688 Ord Way
Oceanside, CA 92056

 1-800-588-0018

 sales@teachlogic.com

 1-760-631-1283

 www.teachlogic.com